

CARRIER STRIP DETAIL

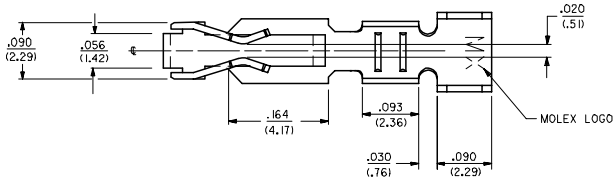

- NOTES:
1. MATERIAL; SEE LEGEND
 2. FINISH:
 - *909 - OVERALL HOT TIN DIF: .000100/(0.00254) MIN.
 - 102 - OVERALL TIN: .000200/(0.00508) MIN.
 - OVERALL COPPER: .000100/(0.00254) MIN.
 - 132 - OVERALL TIN: .000200/(0.00508) MIN.
 - OVERALL COPPER: .000200/(0.00508) MIN.
 - 503 - OVERALL HARD GOLD: .000030/(0.00076) MIN.
 - OVERALL NICKEL: .000050/(0.00127) MIN.
 - 550 - SELECT HARD GOLD: .000015/(0.00038) MIN.
 - OVERALL NICKEL: .000030/(0.00076) MIN.
 - OVERALL HARD GOLD FLASH: .000002/(0.00005) MIN.
 - 555 - SELECT HARD GOLD: .000015/(0.00038) MIN.
 - OVERALL NICKEL: .000030/(0.00076) MIN.
 - 558 - SELECT HARD GOLD: .000030/(0.00076) MIN.
 - OVERALL NICKEL: .000050/(0.00127) MIN.
 - OVERALL HARD GOLD FLASH: .000002/(0.00005) MIN.
 - 561 - SELECT HARD GOLD: .000030/(0.00076) MIN.
 - OVERALL NICKEL: .000050/(0.00127) MIN.
 - * THE PRIMARY SHIPPING CARTON WILL BE LABELED "COMPLIANT TO ROHS DIRECTIVE 2002/95/EC AND ELV ANNEX II OF DIRECTIVE 2000/53/EC." CARTONS WITHOUT THIS LABEL MAY CONTAIN PRODUCT WITH TIN-LEAD PLATING.
 3. PRODUCT SPECIFICATION: PS-40-02
 4. PACKAGING SPECIFICATION: CHAIN FORM SEE PK-6838-001
 5. TERMINAL FOR USE IN HOUSING NOS. 6442 AND 41695
 6. THIS PART WITH CRIMP FOR 22-26 AWG. WIRE. SEE DWG. NO. 7258
 7. CRIMP FOR 18 TO 20 GA. WIRE WITH MAX. INSULATION DIA. OF .100/(2.79). STRIP LENGTH OF .125/100 / (3.18/2.54)
 8. DIMENSIONS GIVEN ACROSS CENTERLINES ARE SYMMETRICAL ABOUT THOSE CENTERLINES WITHIN HALF THE TOTAL TOLERANCE.
 9. THIS PART CONFORMS TO CLASS B REQUIREMENTS OF COSMETIC SPECIFICATION PS-45499-002.

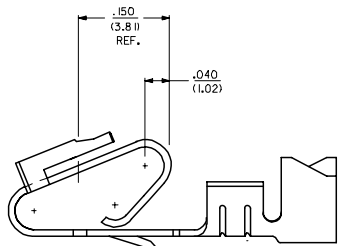

SELECTIVE PLATING LOCATION

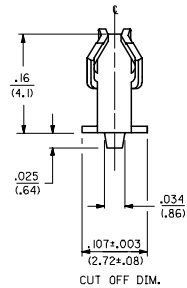

CUT OFF DIM.

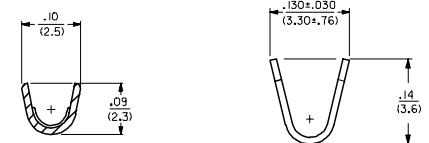
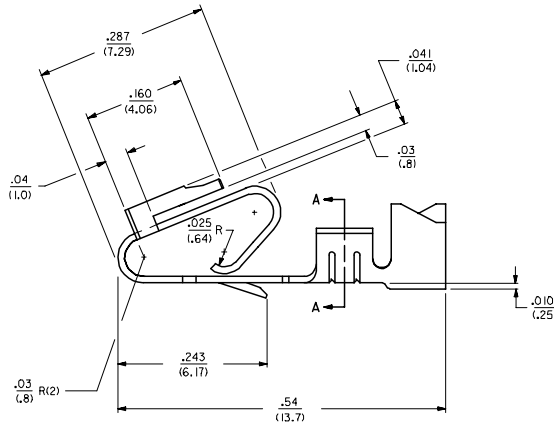

SECTION A-A

- LEGEND: 6838- ()
- WINDING
 - A= PER DETAIL A
 - BLANK= PER DETAIL B
 - FORM
 - BLANK= CHAIN
 - L= LOOSE
 - PLATING
 - SEE NOTE 2
- MATERIAL:
 (.27)/.0106 THK
 BLANK=BRASS
 A=PHOS BRONZE

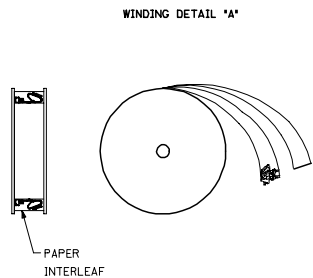

WINDING DETAIL 'A'

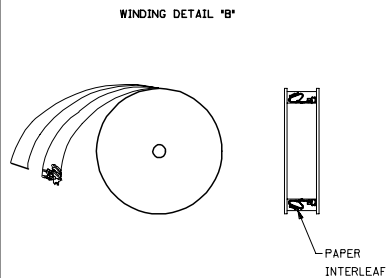

WINDING DETAIL 'B'

ADD NOTE 9 EC NO: UCP2008-0005 DRAWN BY: 2007/07/03 CHECKED BY: 2007/07/09 APPROVED BY: 2007/07/09 APPR: FSN/TH	QUALITY SYMBOLS ▽=0 ▽=0	GENERAL TOLERANCES (UNLESS SPECIFIED)		DIMENSION STYLE		SCALE	DESIGN UNITS	THIRD ANGLE PROJECTION			
				IN/MM		---	INCH				
		4 PLACES ± --- ± ---	3 PLACES ± --- ± .010	2 PLACES ± 0.25 ± .015	1 PLACE ± 0.36 ± ---	DRAWN BY	DATE	TITLE			
		ANGULAR ±1/2°				GUZIK	11/15/89	TRIFURCON TERMINAL CRIMP TYPE, .156 CENTERS 18 TO 20 AWG WIRE			
DRAFT WHERE APPLICABLE MUST REMAIN WITHIN DIMENSIONS				SEE CHART		SD-6838		MATERIAL NO. DOCUMENT NO. SHEET NO.			
				SIZE D		THIS DRAWING CONTAINS INFORMATION THAT IS PROPRIETARY TO MOLEX INCORPORATED AND SHOULD NOT BE USED WITHOUT WRITTEN PERMISSION		1 OF 2			

2 AP2
1 AP2
SHT REV

6838-(*)**		6838-A(*)**													
PART NO.	ENG. NO.	PART NO.	ENG. NO.	PART NO.	ENG. NO.	PART NO.	ENG. NO.	PART NO.	ENG. NO.	PART NO.	ENG. NO.	PART NO.	ENG. NO.	PART NO.	ENG. NO.
08-50-0187	6838-(P909)														
08-50-0189	6838-(P909)L	08-58-0187	6838-A(P558)												
08-50-0275	6838-(P909)-A	08-58-0189	6838-A(P558)L												
08-50-0026	6838-(P102)	08-60-0001	6838-A(132)												
	6838-(P102)L	08-60-0002	6838-A(132)L												
08-50-0028	6838-(102)	08-58-0102	6838-A(558)												
08-50-0029	6838-(102)L		6838-A(558)L												
		08-58-0108	6838-A(503)												
		08-58-0109	6838-A(503)L												
		08-52-0112	6838-A(P909)												
		08-52-0113	6838-A(P909)L												
		08-50-0024	6838-A(102)												
		08-50-0251	6838-A(102)L												
		08-58-0105	6838-A(P555)												
		08-58-0106	6838-A(P555)L												
		08-58-0110	6838-A(P561)												
		08-58-0111	6838-A(P561)L												
		08-58-0118	6838-A(561)												
		08-58-0119	6838-A(561)L												
		08-58-0131	6838-A(550)												
		08-58-0132	6838-A(550)L												

UPDATE TITLE BLOCK DEC NO: UCP2008-0005 2007/07/03 DRAWN BY: JORWANDARR 2007/07/09 CHECKED BY: CHUCK BELL 2007/07/09 APPROVED BY: APPRESMITH 2007/07/09	QUALITY SYMBOLS = 0 = 0	GENERAL TOLERANCES (UNLESS SPECIFIED)		DIMENSION STYLE IN/MM		SCALE ---	DESIGN UNITS INCH	THIRD ANGLE PROJECTION	
		4 PLACES ± --- ± --- 3 PLACES ± --- ± --- 2 PLACES ± --- ± --- 1 PLACE ± --- ± ---	mm INCH	DRAWN BY GUZIK DATE 11/15/89	CHECKED BY PATEL DATE 11/15/89	TITLE TRIFURCON TERMINAL CRIMP TYPE, .156 CENTERS 18 TO 20 AWG WIRE			
		ANGULAR ±1/2°		APPROVED BY LENZ DATE 11/15/89	MOLEX MOLEX INCORPORATED				
		DRAFT WHERE APPLICABLE MUST REMAIN WITHIN DIMENSIONS		MATERIAL NO. SEE CHART	DOCUMENT NO. SD-6838	SHEET NO. 2 OF 2			

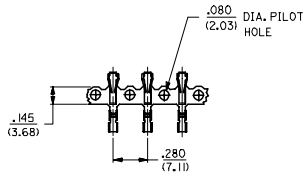

CARRIER STRIP DETAIL

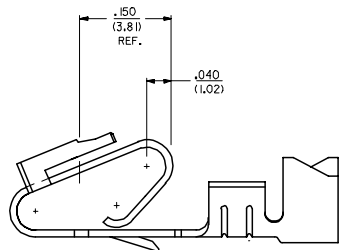

SELECTIVE PLATING LOCATION

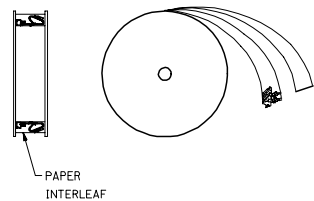

WINDING DETAIL 'A'

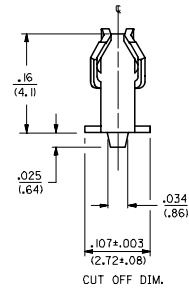

CUT OFF DIM.

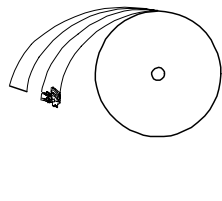

WINDING DETAIL 'B'

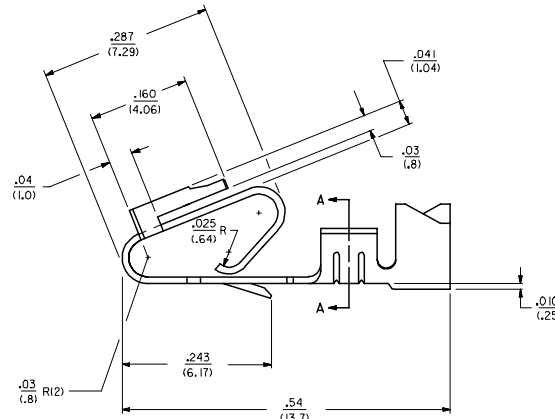
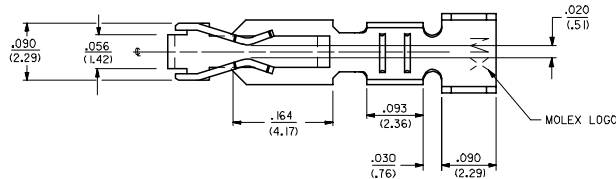

NOTES:

2. CRIMP FOR 18 TO 20 GA. WIRE WITH MAX. INSULATION DIA. OF .110/(2.79), STRIP LENGTH OF .125/.100 / (3.18/2.54)
3. DIMENSIONS GIVEN ACROSS CENTERLINES ARE SYMMETRICAL ABOUT THOSE CENTERLINES WITHIN HALF THE TOTAL TOLERANCE.
4. PARTS CONFORM TO PRODUCT SPEC. 40-02.
5. THIS PART WITH CRIMP FOR 22-26 AWG. WIRE SEE DWG. NO. 7258.
6. TERMINAL FOR USE IN HOUSING NO'S. 6442 AND 41695.

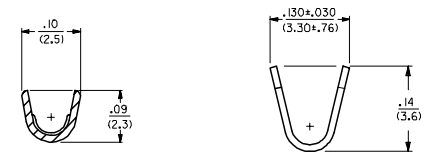

SECTION A-A

LEGEND: 6838- (IP909) • •
 WINDING
 BLANK= PER DETAIL B
 FORM
 BLANK= CHAIN
 PLATING PER SDES-88
 (909) • OVERALL HOT TIN DIP: 2.54 MICROMETERS MIN.

MATERIAL:
 (.27)/.0106 THK
 BLANK=BRASS

*THE PRIMARY SHIPPING CARTON WILL BE LABELED *COMPLIANT TO ROHS DIRECTIVE 2002/95/EC AND ELV ANNEX II OF DIRECTIVE 2000/53/EC.* CARTONS WITHOUT THIS LABEL MAY CONTAIN PRODUCT WITH TIN-LEAD PLATING.

CHANGE TO ME10 EC NO: UCP2005-0959 DRW: NADRI/INOL 2004/11/16 CHKCD: SANIEC 2004/11/16 APPR: MMG/SULLIS 2004/11/16/7 REV DESCRIPTION	QUALITY SYMBOLS ▽=0 ▽=0		GENERAL TOLERANCES (UNLESS SPECIFIED) mm INCH 4 PLACES ± --- ± --- 3 PLACES ± --- ± .010 2 PLACES ± 0.25 ± .015 1 PLACE ± 0.36 ± --- ANGULAR ±1/2°		DIMENSION STYLE IN/MM		SCALE ---	DESIGN UNITS INCH	THIRD ANGLE PROJECTION
	DRAWN BY JJS		DATE 07/29/04		CHECKED BY DATE 07/29/04		TITLE TRIFURCON TERMINAL CRIMP TYPE, .156 CENTERS 18 TO 20 AWG WIRE		
	APPROVED BY DATE 07/29/04		MATERIAL NO. 050291639		DOCUMENT NO. SD-6838-001		SHEET NO. 1 OF 1		
	DRAFT WHERE APPLICABLE MUST REMAIN WITHIN DIMENSIONS		THIS DRAWING CONTAINS INFORMATION THAT IS PROPRIETARY TO MOLEX INCORPORATED AND SHOULD NOT BE USED WITHOUT WRITTEN PERMISSION		MOLEX INCORPORATED				